

Custom Cascade

Step Scupper Quotation Form

Call 800-420-3255, Dial Opt. 2

Fax form to 800-434-7660

Visit our website @ oreqcorp.com

Company Name: _____ Phone: _____
 Address: _____ Fax: _____
 Contact: _____ Distributor: _____

1. Choose Material: (select one)

Stainless Steel

Brass

Copper

*Patina options (select one)

Brushed Finish

Brushed Finish

Brushed Finish

Antique

Polished Finish

Patina Finish*

Patina Finish*

Verde

Antique Verde

2. Choose Length: A= _____
 (8" - 36" Available)

***Back Inlets Only**
 (units over 2' may have multiple inlets)

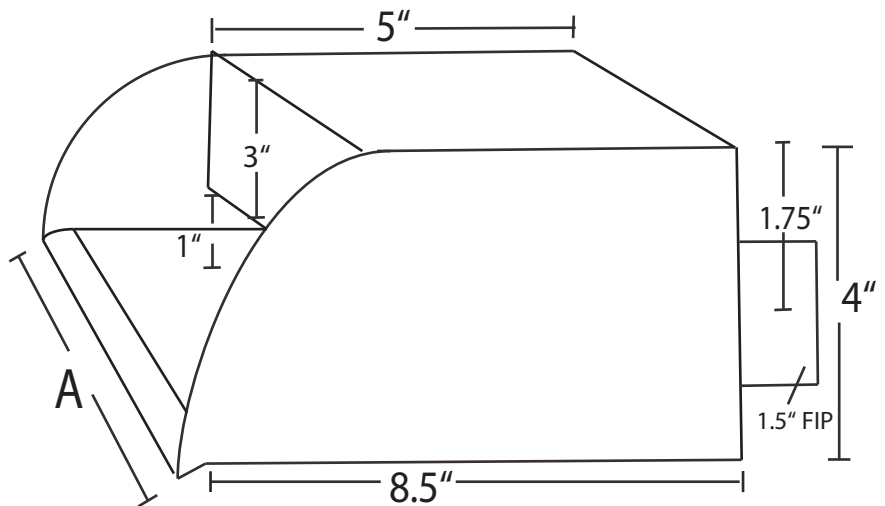

3. Order Quantity : _____

| | | |
|---|---|-------------------|
| OREQ USE ONLY | | Date _____ |
| Custom Part Number _____ | | Quote # _____ |
| Description _____ | | |
| Quotation Amount (sug. list \$) _____ | | each |
| <input type="checkbox"/> Crate Required (Flat Fee) \$ _____ | <input type="checkbox"/> Deposit Amount Required \$ _____ | |
| Lead Time (Business Days) _____ | | Quoted By _____ |

Customer Approval Signature _____ **Date** _____

Check form carefully - custom and all metal units are non -returnable/non-cancellable.

Quotes are subject to change after 30 days, and do not include freight.

All Credit Card customers will be required to pay full amount up front on Custom & Standard Water Features.

This form is for quotation purposes only. A purchase order is required to begin processing.

WARNING: Metal products are not recommended in conjunction with salt chlorinator systems. Salt chlorine systems often cause rusting, corrosive condition for metal waterfalls. Metal products used in conjunction with salt chlorine generator systems void manufacture warranty.